

TRANSLICER® 2510 CUTTER

LARGE PRODUCT, HIGH CAPACITY SLICER/SHREDDER

The TranSlicer 2510 Cutter accepts compressible food products up to 8" (203 mm) in diameter, or firm products up to 6-3/4" (171 mm) in diameter — precutting may be necessary. Optional static hold-down assembly is available to maintain positive feeding assistance.

Interchangeable stainless steel cutting wheels include: slicing wheel, julienne wheel, and shredding wheel. The number, placement, degree of pitch, and type of knives coordinate with the cutting wheel and feed belt speed to determine the size of cut. The 2510 continues to dominate the fresh salad industry for the processing of all different types of leafy vegetables and packaged salad kits. The machine features sanitary, stainless steel design, and continuous operation for uninterrupted production.



TYPES OF CUTS



A. SLICING WHEEL

Flat and Crinkle Slices: 1/32 to 3" (.8 to 76.2 mm)

B. JULIENNE WHEEL

Julienne cuts ranging from 3/8 x 3/8" to 3 x 2" (9.5 x 9.5 mm to 76.2 x 50.8 mm) can be produced by using julienne knives on the cutting wheel.

C. SHREDDING WHEEL

Shred cuts ranging from 3/8" (9.5 mm) to approximately 3" (76.2 mm) in length and 1/32 to 9/32" (.8 to 7.1 mm) in slice thickness can be produced by using a combination of julienne and slicing knives to make up the shredding wheel.

1 CELERY
3" (76.2 mm) Stick
1/2" (12.7 mm) Slice

2 EGGPLANT
3/16" (4.8 mm) Slice

3 ICEBURG LETTUCE
1/8" (3.2 mm) Shred
1-3/8 x 1-1/2"
(35 x 38 mm) Square

4 KIWI
3/16" (4.8 mm) Slice

5 PAPAYA
3/4" (19.1 mm) Dice

6 RED CABBAGE
1/8" (3.2 mm) Shred

7 ZUCCHINI
3/16" (4.8 mm) Slice

CUTTING OVERVIEW

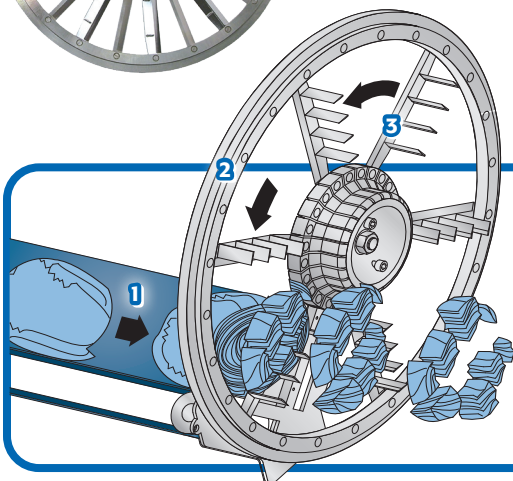

1. Feed Belt
2. Julienne Wheel
3. Julienne Knives

If your product application is not mentioned on this page, contact your local Urschel representative to determine the most effective solution to your size reduction needs.

TRANSLICER® 2510 CUTTER

Measurements and weights may vary depending on machine configuration.

Length:.....150.82" (3831 mm)

Net Weight:1,500 lb (680 kg)

Width:.....49.88" (1267 mm)

Cutting Wheel Motor: 3 HP (2.2 kW)

Height:.....66.75" (1695 mm)

Feed Belt Motor:.....1 HP (.75 kW)



SPECIFICATIONS & DIMENSIONS

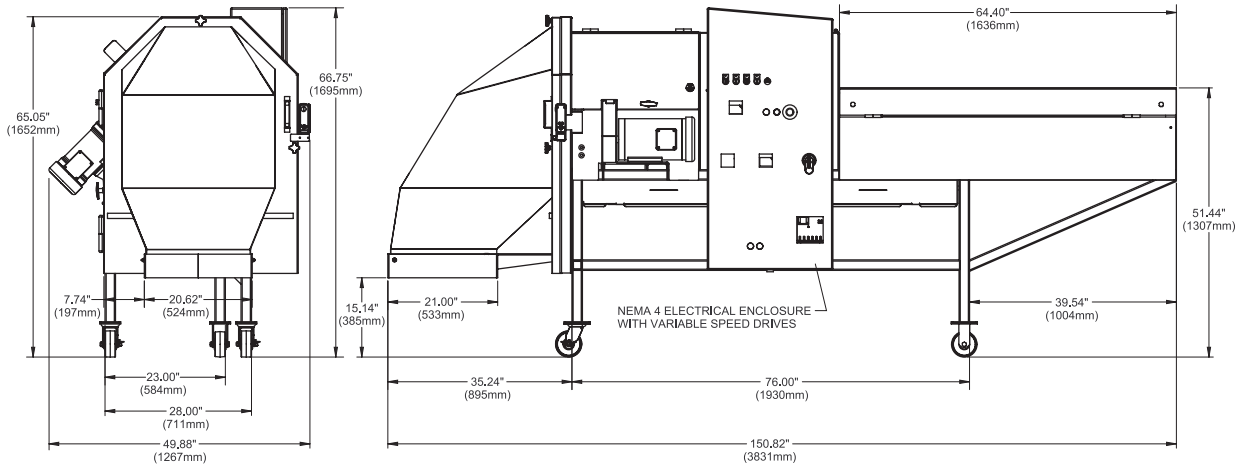
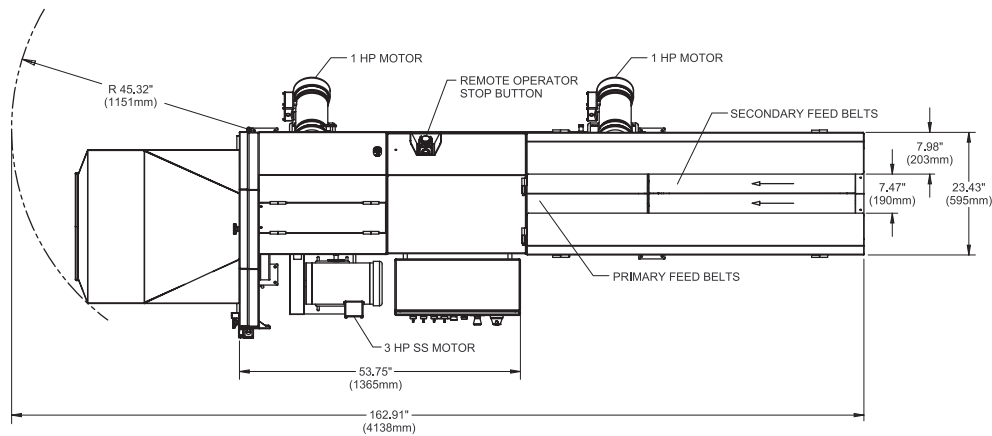

TEST CUT YOUR PRODUCT

Contact your local Urschel representative to schedule a comprehensive, no-obligation test-cut of your product: www.urschel.com.



URSCHEL®

The Global Leader in Food Cutting Technology

www.urschel.com | ✉ info@urschel.com